

Ensuring the Safety of Medical Electronics

James Richards, Marketing Engineer

The purpose of safety testing medical electronic equipment is to be sure that a device is safe from electrical hazards to the patient and caregivers. There are a number of UL, European and Canadian standards that serve as the ruling body on how medical products will be tested, one in particular, IEC60601-1 (the International Electrical Safety Standard for medical electronic equipment) is experiencing “global harmonization,” meaning it is being accepted and implemented around the world. The IEC60601-1 standard is mainly intended for product development where safety considerations must be taken into account early in the design phase of a product, however much of it is applied to production line testing since it is the only way for a manufacturer to be sure they are shipping safe product.

Vital areas of electrical safety testing for medical products include leakage current, dielectric breakdown, insulation resistance and ground bond testing. To better understand the differences in these tests and others, this article examines the purpose and techniques for each test then offers a detailed discussion.

Ground Bond/Continuity Testing

The ground bond or continuity test should be the first electrical safety test on a product following visual inspection and is performed on many electrical products, including consumer appliances as well as medical products. The test checks the connection from any user exposed or user accessible metal parts to the earth reference on the product’s line cord. The test involves the measurement of the resistance of this connection with the intent being that sufficient current will flow to earth through this connection (not through the operator) in the event that a product should fail and a user accessible surface come in contact with a live voltage.

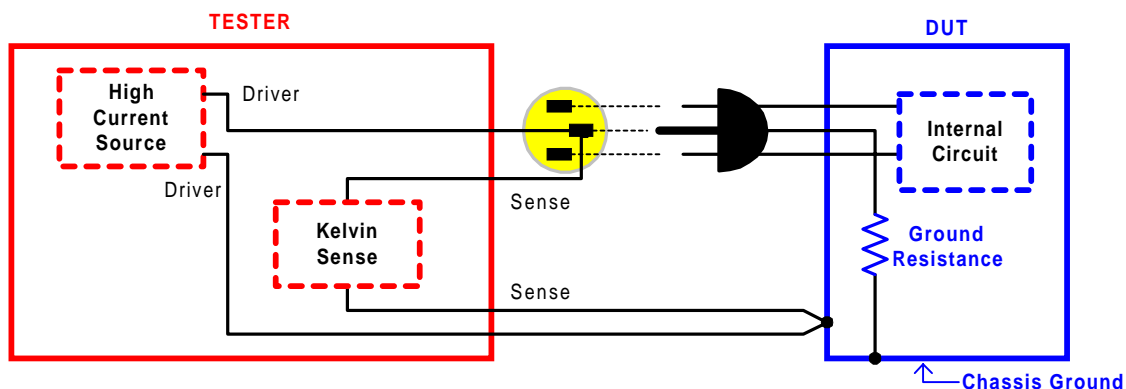

Figure 1: Setup for Ground Bond Test

Ground Bond/Continuity Test

Many product standards require that the presence of this continuity connection be verified during production testing. One method of doing this is with a low current “continuity test” which verifies that the connection is present but not necessarily capable of handling high current should a product’s insulation fail. Verifying the presence of this connection is one thing, verifying the integrity is another, thus the term, “ground bond test,” and the two tests should not be confused. The low current continuity test is adequate for safety testing of many products but not for many of the European Norm (EN), IEC, CSA and some UL standards, particularly those aimed at medical equipment. IEC60601-1 specifically says that user accessible conductive parts connected to the safety ground be tested with a current of 25 Amps or 1.5 times the product’s current consumption, whichever is greater. This current shall be from a source with a maximum no load voltage of 6 volts AC. Other medical standards allow variations where the maximum voltage can be up to 12 volts, AC or DC. The 12V, or less value, is used to limit the test operator to hazardous voltage levels. The resistance of this ground path is the important parameter calculated from the test current and voltage drop and it should be less than 0.1 ohms on equipment using a detachable power cord, or 0.2 ohms when using a permanently attached power cord. It is wise to verify the ground integrity of the product before applying high voltages that might jeopardize the test operator.

Hipot Test

The Hipot test, often called the voltage breakdown or dielectric withstand test, is intended to electrically stress a product’s insulation beyond what it might encounter in normal use. The end goal being assurance that the product will function as designed and not cause any harm to the product’s user. Hipot testing has been around in various forms for decades governed by many different standards that required product to be tested before it can exit a manufacturers production line, and medical products are no exception. The rule of thumb, in most standard requirements, is to apply a test voltage two times the normal operating voltage plus 1000V, this being 1250 or 1500 VAC depending if the product is to be operated at 115 or 240 VAC. This is usually a sinusoidal AC voltage, but in some cases a DC voltage typically higher by a factor of 1.414 can be substituted. For hard-wired corded product, the test voltage is applied between the high (hot) and neutral conductors shorted together, and power ground or exposed metal parts. During this test the product’s power switch should be in the “on” position and of course the unit is not powered up and running. See Figure 2.

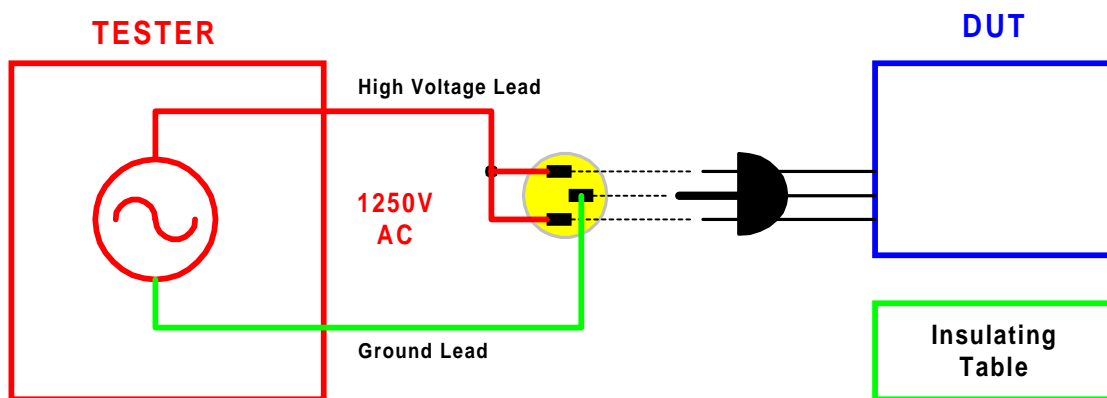

Figure 2: Typical AC Hipot Test

Hipot Testing

The test voltage is raised from zero to the predetermined test voltage and typically held for 1 minute. No breakdown should occur during this test, a breakdown being defined as a rapid increase in current across the tested insulation. Most hipot testers usually allow the operator to program a maximum and minimum current level. Nearly all products will have some leakage current during this test due to inherent capacitance properties and filtering. Besides the maximum limit, above which the product is considered to have failed, a minimum current limit can be used to serve an important function. If the device current is below a minimum limit this is a good way of determining that the tester is not making the proper contact with the test device.

If a product passes a Hipot test it is unlikely to cause an electrical shock in its normal use. By stressing the product to a very high voltage over what it would normally see means there is a large margin of safety existing for the protection of the user.

Line Leakage Current Test

Leakage current measurements associated with the dielectric withstand test or hipot test were discussed earlier, but line leakage current is something quite different. The hipot test detects excessive leakage current through a product's insulation system as the result of a deliberate over voltage condition. The line leakage test detects leakage current at normal operating voltage, not at over voltage. It measures the current through a simulated human body impedance while the product is turned on and powered up at normal operating conditions.

The leakage test is intended to measure current flow through various parts of the product, one being through the ground system, another from the product enclosure to ground and the last being in, out, or between patient accessible parts. If these currents are excessive it can result in an electrical shock to the user or patient. Because of this potential hazard, safety agencies have set standards for the maximum amount of current that may leak from a non-defective product. Since hipot tests are usually required for 100% of electrical products in a production line, and since hipot tests are more stringent, line leakage tests are normally specified as a design test rather than a production test. However, line leakage tests are typically required on **medical products** as a production test, the purpose being to ensure that a device is safe for the patient and caregiver. Just by their very nature, health reasons alone can place a medical patient at higher risks from electrical shocks, thus the reason for the added caution.

Medical device standard IEC60601-1 is the most widely recognized standard with detail regulations for the design of safe medical electronic equipment. The leakage testing content of this standard is too extensive to discuss here and is mainly intended for product development where comprehensive testing is done under many different test conditions, however some parts are typically used in a production line environment.

Leakage Current Test

One of the most important and critical tests specified in IEC60601-1 is conducted with a circuit similar to that shown in Figure 3 and known as earth leakage current. This is essentially a sum of all leakages in the product under test, or basically the current flowing back to earth ground through the ground conductor of the line cord. This test needs to be done under different “normal” conditions and “single fault” conditions. Normal conditions are electrical conditions that might normally occur on regular basis and are not considered a problem. An example is a reversed AC line that is simulated by S1 in Figure 3.0. A single fault is a problem that could occur, and since its unlikely that two faults would occur together, faults are tested one at a time. An example of a single fault is an open neutral which is simulated by S2 below. This test is made with normal and reversed line (S1), and open and closed neutral (S2).

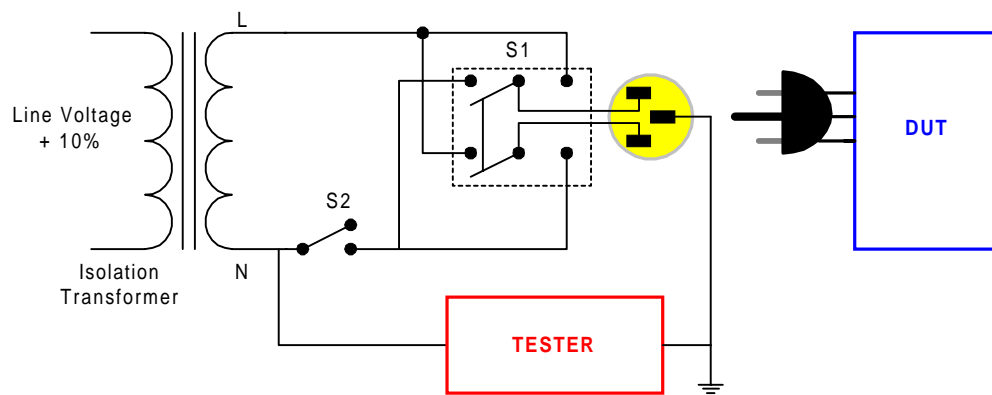

Figure 3: Line/Earth Leakage Test

An important thing about line leakage measurements is the actual measurement device being used. Standards require the use of meters with very specific loads, where the load simulates the impedance of the human body. An equivalent circuit of the human body consists of a 1000Ω resistor in parallel with the series combination of a $0.015\mu\text{F}$ capacitor and $10\text{k}\Omega$ resistor. Figure 4 shows the test load required.

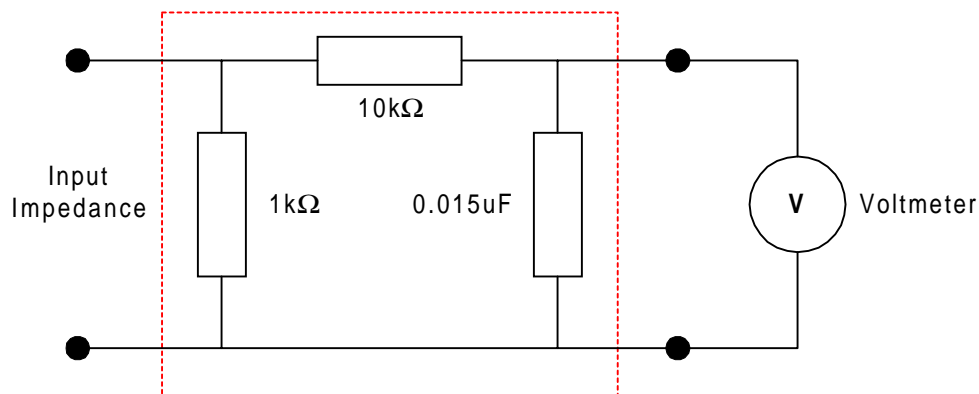

Figure 4: Human Body Equivalent Impedance

Power Consumption

Besides the tests previously described, IEC60601-1 specifies additional tests that verify the normal operation of a product. One is for Current Draw, which measures the current that a product under test is consuming through the power cord. This is done with the power applied and the instrument under normal operating conditions. The actual current must be within 10 to 25% of the rating marked on the product. Another test is for Power Consumption, which measures the power the product under test is consuming while operating. The power consumption should not be more than 10 to 15% above the rated marking on the product. This test should be done with equipment controls set for maximum output and the measurement should be for True power.

Conclusion

There are a number of manufacturers who produce electrical safety testers for the tests discussed above. Many testers perform just one type of test while others perform multi-functions or several tests in the same box. Testers that offer the capability of AC Hipot, DC Hipot, ground bond, insulation resistance and line leakage measurements are not uncommon. These multi-function testers are now becoming popular in product development or production areas where more comprehensive testing is already being implemented or anticipated in the near future. Technology has progressed to the level where an instrument can provide much greater capability for the same or less money, all of which makes for easier, faster, and more complete product testing. Standards may serve as the basis for shipping safe product into the medical industry, but the ultimate responsibility for these safe products rests with the manufacturer's test process and equipment employed.



Figure 5: QuadTech's 6100 Safety Analyzer for Medical Products

For complete product specifications on the 6000 Series Electrical Safety Analyzers or any of QuadTech's products, visit us at <http://www.quadtech.com/products>. Do you have an application specific testing need? Call us at 1-800-253-1230 or email your questions to info@quadtech.com.

The information presented here is subject to change and is intended for general information only

©QuadTech, Incorporated

Telephone: 1- 800-253-1230, Website: <http://www.quadtech.com>

Printed in U.S.A.

P/N 035111/A2

June 2003